

# Protective Spark Gap

Ref.	P8760
Application	For indirect connection of an overhead line roof pole to the external lightning protection system
Power frequency sparkover voltage (50Hz)	≈ 10 kV
Nominal discharge current (8/20μs)	25 kA
Material (connection)	inox
Degree of protection	IP 54
Weight	0.175 kg

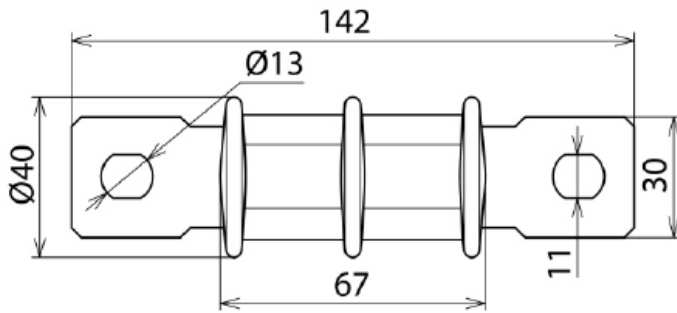

Dimensions (mm)



Basic circuit diagram

