

Earth clamp

Characteristics	P8004
Material	Copper
Weight (Kg)	0.130
Application	Used to fix tape (lightning conductor earthing) to copper cable (mains earth).

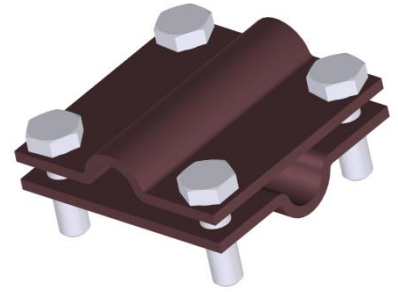

Dimensions (mm)

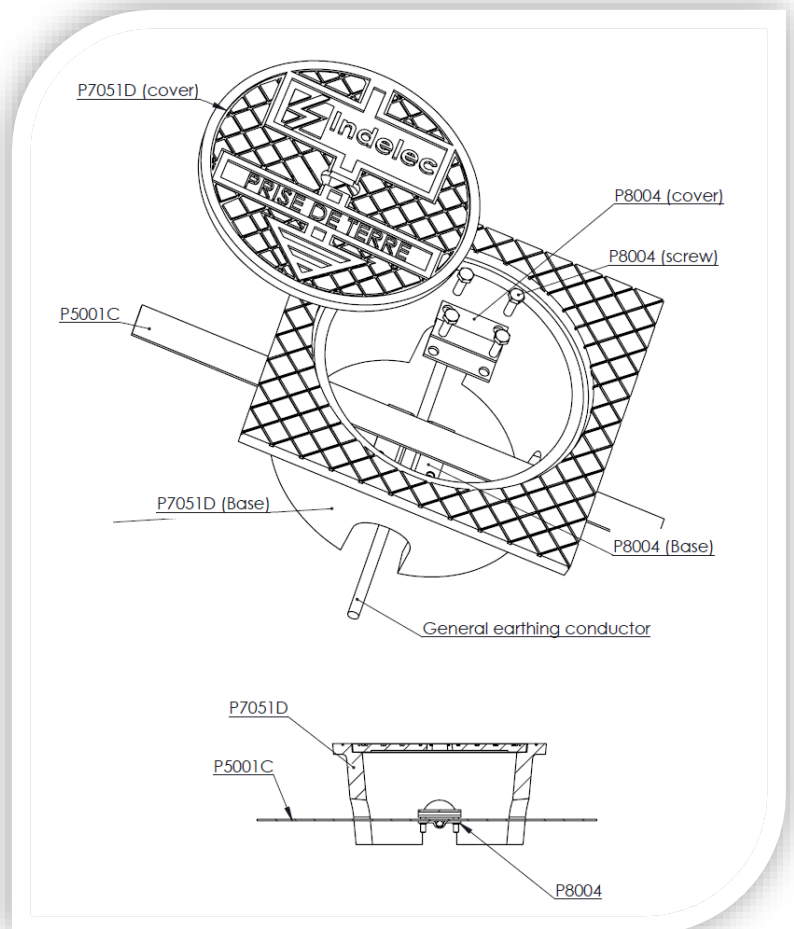
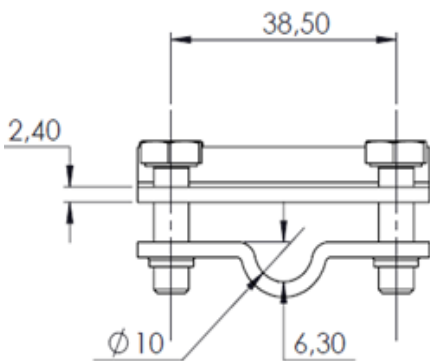
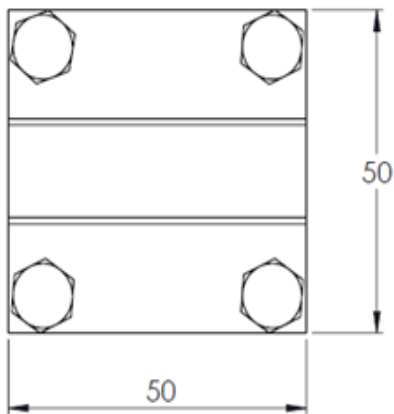

Application

DOC224a_VEN-Rev0

