

# Factory-Made « Crow Foot » Earthing

Characteristics	P7021
Material	Tinned copper
Weight (kg)	12.000
Application	«Crow-Foot» earthing system consists of three 7- meter prongs angled at 45° and a 3-metre long central prong which is connected to the test clamp. This earthing system is easy to unroll and bury. It avoids mechanical connections which would be prone to corrosion over time

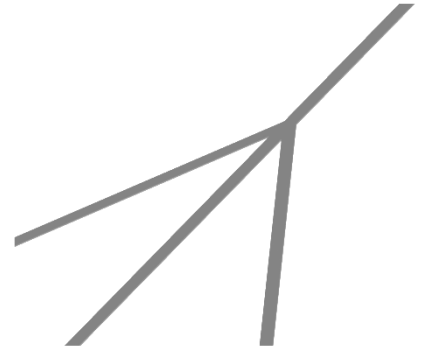

## Dimensions (mm)

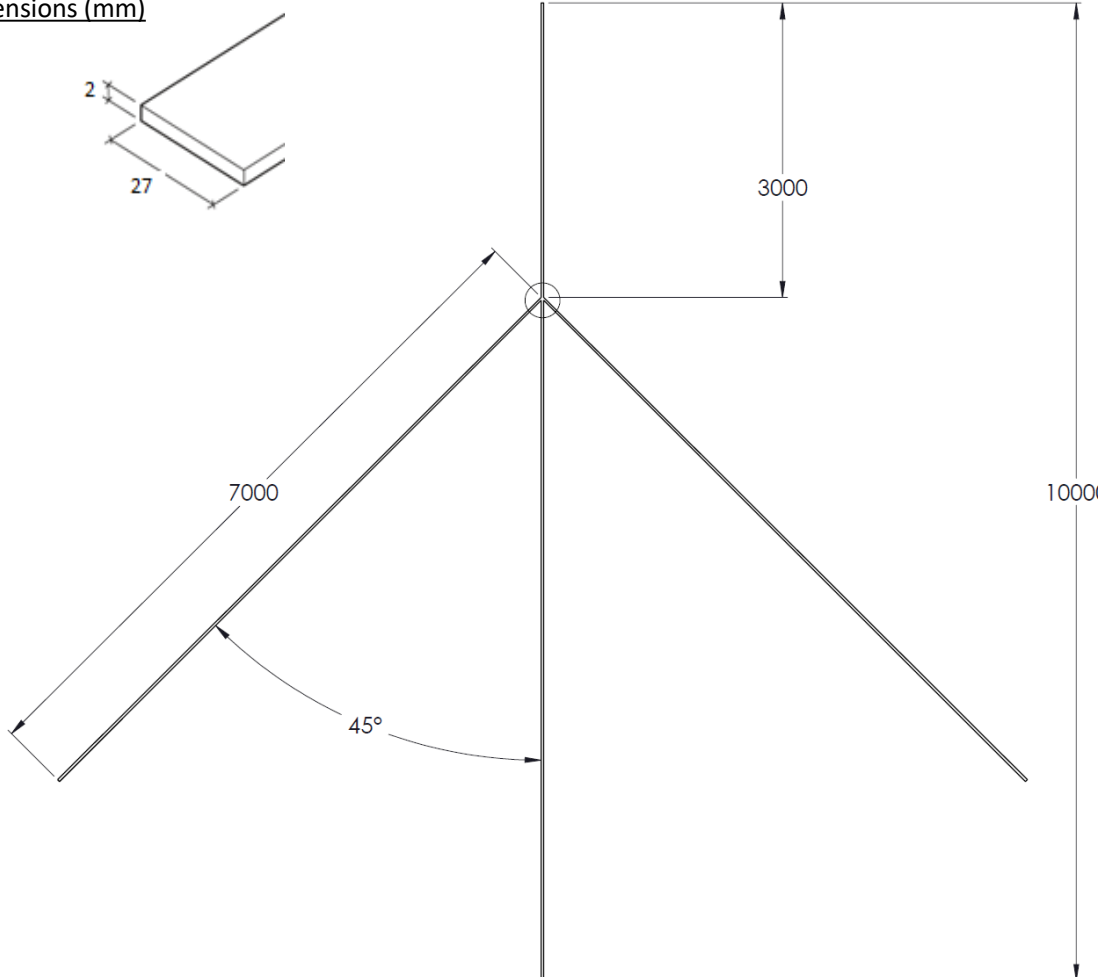

DOC215a.VEN-Rev0

