

Slate Holdfast for Tape

Characteristics	P6011	P6012
Material	Tinned copper	
Weight (kg)	0.065	0.030
Thickness (mm)	1	1
Application	Used to fix tape on a tile or slate roof. The mounting is pushed in between two tiles and the two flanges folded back to hold the conductor in place	Used to fix tape on a tile or slate roof. The mounting is pushed in between two slates and the conductor is welded on.
Standard	EN 62561-4	

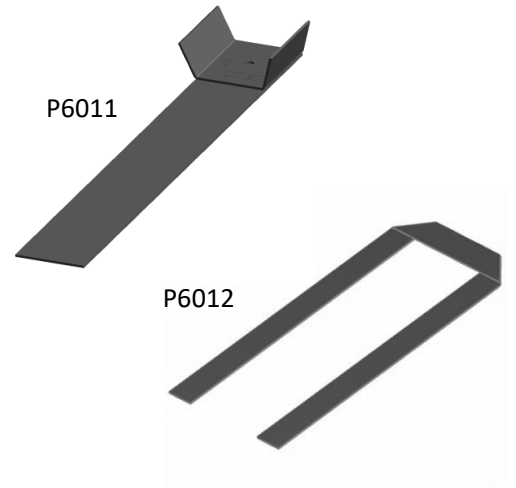

Dimensions (mm)

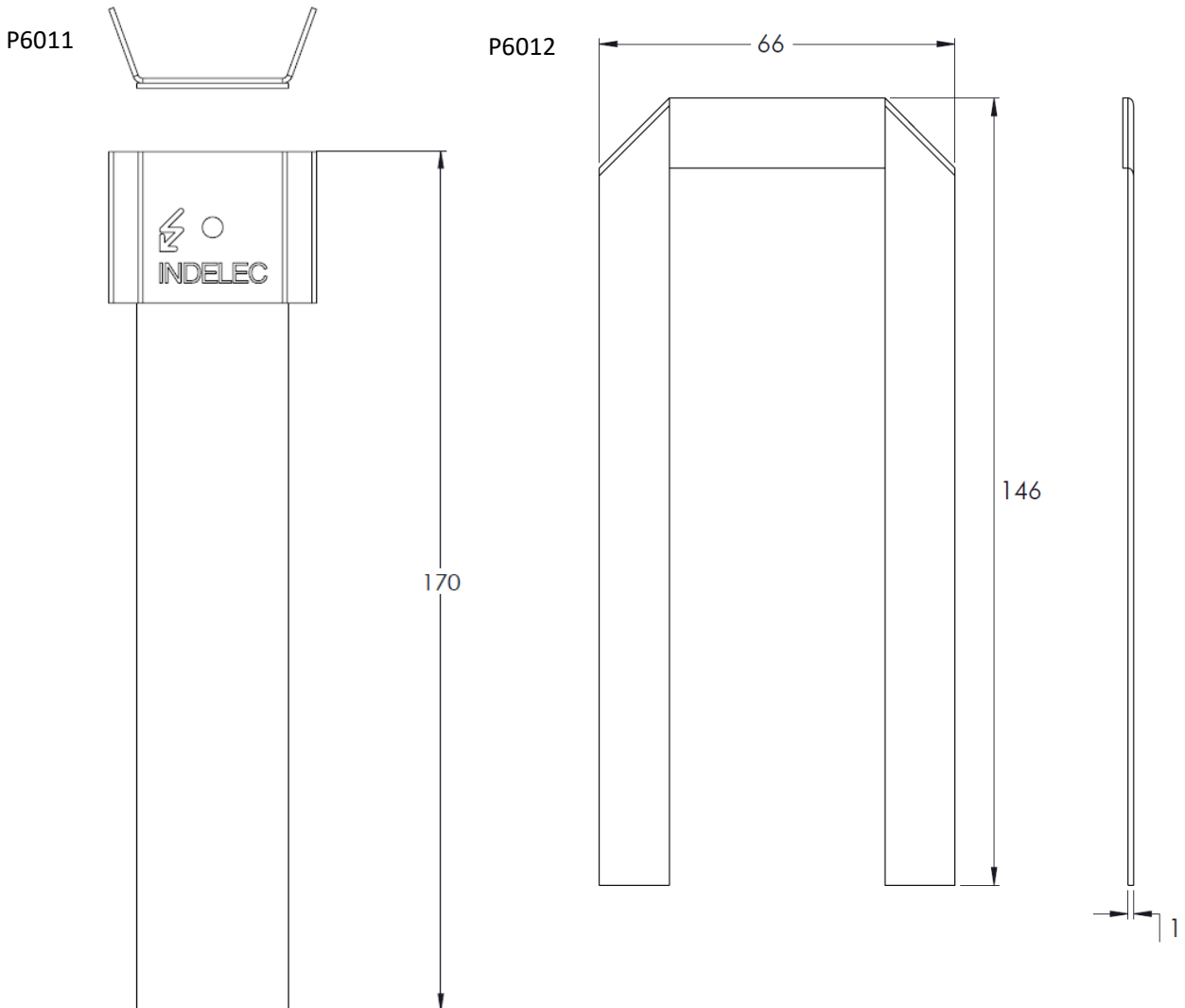

DOC193a.VEN-Rev0

