

High voltage lines

LBIA Type A > 10 Cd



Description:

The LBIA BHT is a one block beacon with the LEDs technology.

Dedicated to the beaconing of high voltage lines, it is a long life beacon (100 000 hours), without any power supply. This compact design and light weight allow the quickest and easiest installation on the market.

Advantages :

- Long life time > 10 years
- Multi – LEDs
- Natural stability based on specific nut
- Installation time reduced
- No maintenance
- Warranty 2 years
- Product completely fulfil with high voltage resin to avoid vibration effects
- Only 1 reference for all voltage of lines

Applications :

The LEDEOBIA BHT complies with the ICAO regulations as it is power supplied by the magnetic field around the cable of the high voltage line. This light can be used for beaconing high voltage lines up to 500kV. The installation specifications for high voltage overhead cables are mainly dealing with the intervals between two beacons:

- 70 meters for sensitive specification location in the vicinity of an airport
- 105 meters for other locations Moreover, the light cannot be fixed at less than 10 meters from the closest supporting tower.



Regulations:

- ICAOI
- CE

Scope of application:

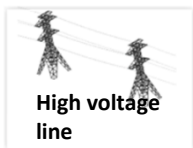

Models

Model	Voltage of the lignes	Photocell	Dry Contact
LBIA00HT	1V to 500kV	Not included	Not Included

DOC107a_VEN-Rev1



High voltage lines LBIA Type A > 10 Cd

Characteristics

Luminous	
Luminous intensity	LEDS
Colour	Red
Horizontal beam	360°
Vertical beam	10°
Luminous intensity	>10 Cd
MTBF	100 000 Hours
Electrics	
Voltage lines	1V to 500kV
Functioning temperature	-55°C to +55°C
Current Imin	7A
Current I10Cd	10A
Current Imax	800A
Protection class	IP66
Mechanicals	
Body material	Aluminium ABS
Lens material	Polycarbonate with peak against birds
Mounting	Positioning nut
Height	380mm
Width	215mm
Weight	<6 Kg
Environment	
Humidity	100%
Frost	-60°C
Wind speed	240 Km/h
Certifications	
	EN60947-1
CE	CEI60364, NF C15-100 EN60529
ICAO	Annexe 14, Volume I, Chapter 6
Quality	ISO 9001 ; 2008
Warranty	2 years

Installation

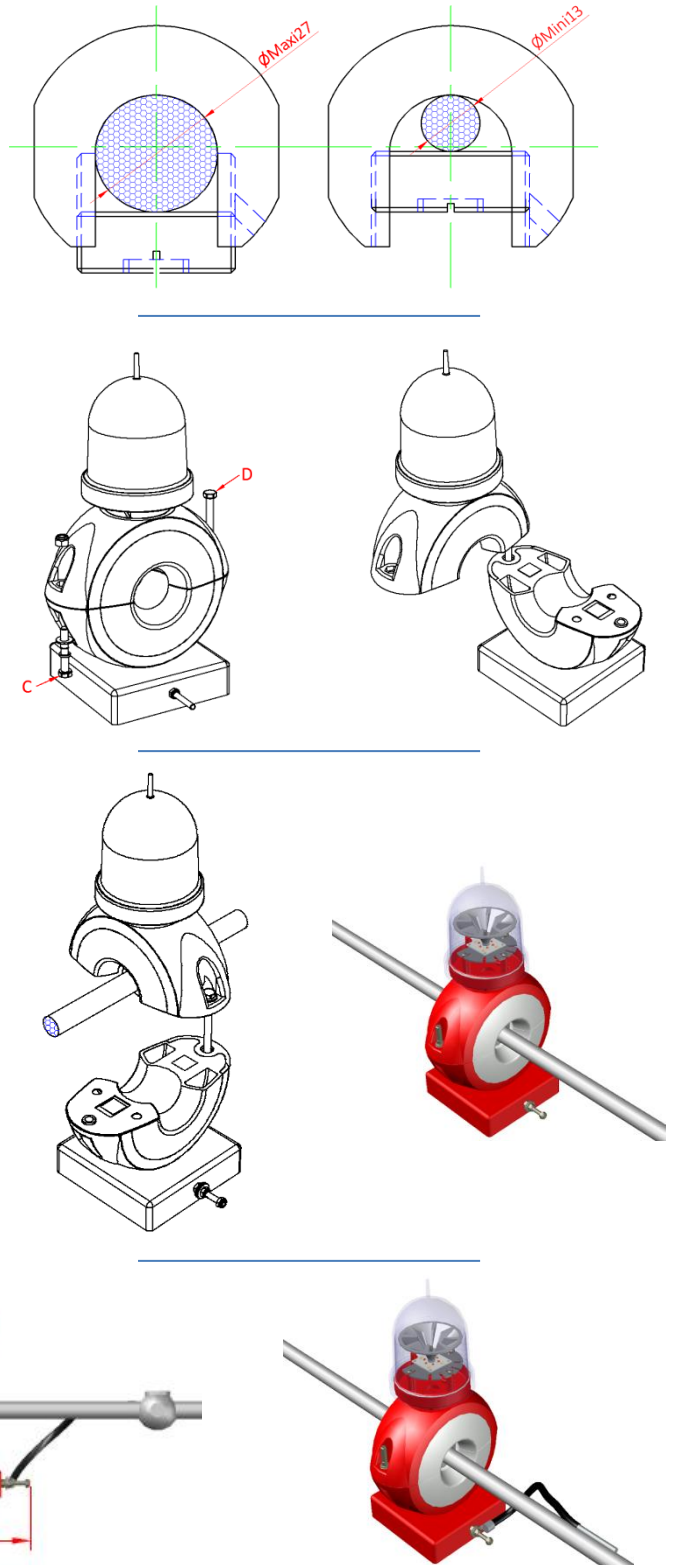

Dimensions :

